

# Teamwork Global Group Ltd

## 天沃环球集团有限公司

ROOM A1, 11/F WINNER BUILDING, 36 MAN YUE STREET, HUNG HOM, KOWLOON, HONG KONG

POST CODE:999077 Tel:0086-0755-85265699 Fax:0086-0755-85266599

## Production Confirmation Sheet

### 生产规格确认书

Customer Motor model (客户马达型号) : 5425-230V-50Hz

TW Motor model(我司马达型号) : UM5425M23

TW Motor type(马达类型) : AC UNIVERSAL MOTOR

Customer PO Number (客户订单号) :

Prepared by (作成) : Celine Lee

Date (日期) : 2023.05.31

Approver by (批准) : Leo Lee

Date (日期) : 2023.05.31

客户确认签名: CUSTOMER APPROVED SIGNATURES

此为正式生产确认数据,我方将严格按照此技术数据批量生产

This is formal technical data,all mass order production will be followed exactly according to this approved technical file

1

2

3

4

5

6

ISSUE NO:

GSEN-1-2107

EDITION:

A

B

C

D

A

B

C

D

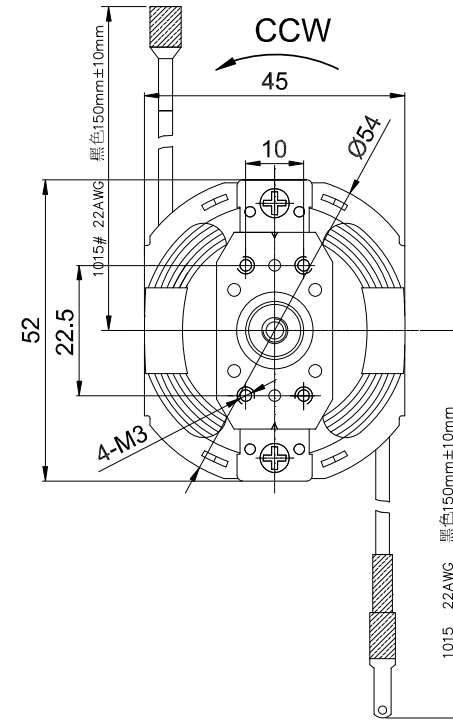
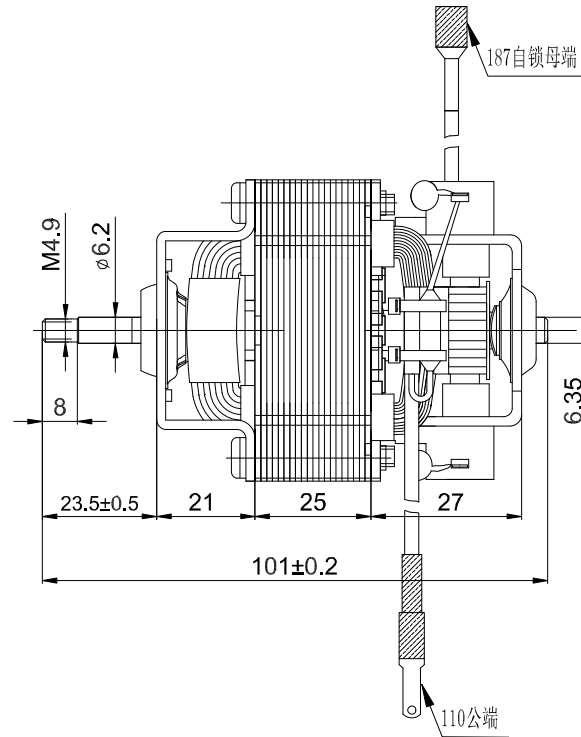
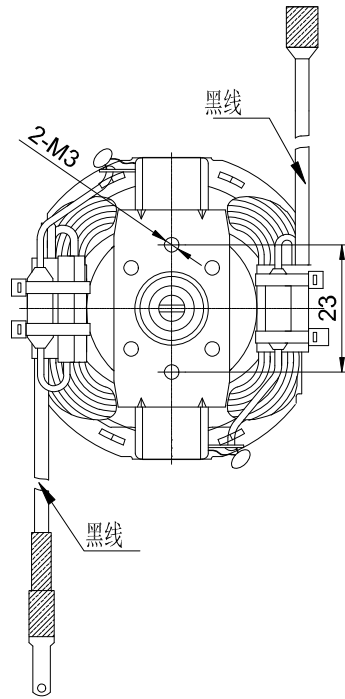

技术要求/Tech:

1. 额定电压/Rated Voltage:  $\Delta C230V$  50Hz
2. 空载转速/No load Speed:  $27000 \pm 15\%$
3. 原子线/Lead Wire: 1015 22AWG E189674
4. 耐压测试/H.V: 1800V/5mA/1S
5. 绝缘阻抗/Resistance:  $\geq 20M\Omega$
6. 绝缘等级/Insulation: CLASS B
7. 电机轴表面光亮、无损伤、无锈迹
8. 螺丝紧固、无松动, 松脱扭力 $\geq 5Kgf.cm$
9. 引线拉脱力 $\geq 3Kg$
10. 尼龙扎带绑扎牢固, 浸漆均匀, 无漆瘤
11. 电机外观良好, 铁芯无生锈、伤痕、残缺、无变形
12. 电机铭牌字体工整、清晰

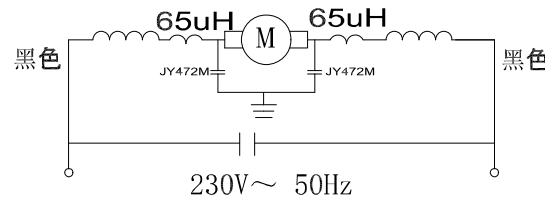

标签内容 (Label)

UM5425M23
20230531

DRAWN	钟剑军	DATE	31/05-2023	TITLE	Motor Outline drawing	SCALE	1:1	UM5425M23
AUDITOR		DATE		Checked	±0.3	公差	±3%	SCALE
APPROVED		DATE		天沃环球集团有限公司 Teamwork Global Group Ltd				

1

2

3

4

5

6

# Teamwork Global Group Ltd

## 天沃环球集团有限公司

### 1、Standard Operating Conditions (标准使用状态) :

1.1 Type: (电机类型)	Universal Motor (通用电机)
1.2 Rater Voltage/Rater Frequency: (额定电压/额定频率)	230V 50Hz
1.3 Direction of Rotation: (旋转方向)	CCW (the motor output shaft end to observe 面对电机输出轴观察)
1.4 Work Position: (工作位置)	Vertical /Horizontal (竖直的/水平的)

### 2、Motor Electric Performance (马达电气性能) :

2.1 Free Load point test: (空载点测试)	230V 50Hz Free load measurement at 10-15sec
2.2 Free Load Current: (空载电流)	0.3±15% (A)
2.3 Free Load Speed: (空载转速)	27000±15% (rpm)
2.4 Free Load Power: (空载功率)	70±15% (W)
2.5 Free The spark degree: (空载火花等级)	≤1.5
2.6 Hi-Pot test: (耐压测试)	1800V 5mA 1Sec
2.7 Insulation Class: (绝缘等级)	Class B (130 °C)
2.8 Noise: (噪音)	≤85dB,1m处, 环境噪音参考≤50dB.

### 3、Structure and Mechanical Propertiec (结构和机械特性) :

3.1 Motor Protection (电机保护方式) :	无
3.2 EMC filter (电磁兼容过滤线路) :	电容 JY472 电感65uH
3.3 Motor Security Standard (电机安全标准) :	IEC60335

### 4、Motor Marking (马达印字) :

4.1 Conten (内容)	
UM5425M23	Motor model No (电机型号)
YYYY MM DD	YYYY MM DD Date of manufacture e.g 2022.03.05 (YYYY MM DD 指生产日期, 如2022.03.05)

### 5、Checking and Acceptance (检验标准) :

5.1 All the testing and measurement are based on this specification sheet (本公司所有的检测项目以及检测规范依照本规格书执行)
5.2 The ruler to check the motors is by sampling. For those normal items the AQL=1 and for the critical margin the AQL=0.65. (本公司产品检验采用抽验的方式。针对一般项目采用 AQL=1, 针对严格项目 AQL=0.65。)

### 6、The attachment drawing (附件图纸) :

6.1 Outine drawing (产品外形图纸) : UM5425M23	A total of one page (共1页)
---	---------------------------

### 7、Remarks (备注) :

7.1 Thanks very much for your choosing TW motor. TW motor will continuously provide you the best products and service.

(感谢贵司使用天沃电机产品。天沃电机秉承一贯传统快捷准确提供电机产品以及服务给我们的客户)。

7.2 Please note that it's your responsibility to ensure that this motor can satisfy the requiremennt of your application.

(尊敬的客户务请留意: 你有职责确认本司的电机产品是完全符合贵司的产品的要求的)。

# Teamwork Global Group Ltd

## 天沃环球集团有限公司

### Motor sample test report

电机型号/Model	UM5425M23	测试电压 (V)/频率 (Hz)	230V 50Hz	日期	2023.05.31
------------	-----------	------------------	-----------	----	------------

检查项目/Item:

测试项目	规格/Standard	1	2	3	4	5					
空载转速 Load S.-H No	27000±15% (rpm)	28080	26480	27560	27200	28100					
空载电流 Load C.-H No	0.3±15% (A)	0.29	0.3	0.29	0.31	0.28					
空载功率 Load P.-H No	70±15% (W)	67	70	69	71	66					
轴伸/Shaft	23.5±0.5 (mm)	23.4	23.5	23.6	23.6	23.6					
原子线/黑/B Wire	150±10 (mm)	1148	150	152	150	150					
原子线/黑/B Wire	150±10 (mm)	151	154	153	149	149					
马达印字	清晰, 美观	OK	OK	OK	OK	OK					
马达外观	无生锈、披锋	OK	OK	OK	OK	OK					
耐压测试	1800V 5mA 1Sec	OK	OK	OK	OK	OK					
转向 (输出端)	CCW	CCW	CCW	CCW	CCW	CCW					

备注											
测试	钟家乐			确认			钟剑军				
日期	2023.05.31			日期			2023.05.31				

输入功率 W	电流 A	电压 V	效率 %	输出功率 W	转速 rpm
400	2	250	60	150	25000
360	1.8	225	54	135	22500
320	1.6	200	48	120	20000
280	1.4	175	42	105	17500
240	1.2	150	36	90	15000
200	1	125	30	75	12500
160	0.8	100	24	60	10000
120	0.6	75	18	45	7500
80	0.4	50	12	30	5000
40	0.2	25	6	15	2500
0	0	0	0	0	0

